

SERIE 828-44.

Surface mount electromagnetic lock suitable for door locking applications. This device was supplied with a electromagnetic device in aluminium housing and the armature plate as well as different accesories for an optimal installation. The most important advantages of these devices are:

- Their particular installation friendliness
- They are ideal for retrofitting in doors with access control
- Practically zero wear, thanks to their structure and functionality

Technical Features

- Fail Safe (Door Unlocked when power off).
- Holding Force: 5.000N
- Rated operating voltage: 12 or 24V DC
- Current consumption: 630mA at 12V DC or 315mA at 24V DC
- Integrated contact for the locking signal (Hall sensor)
- Max. contact rating: 2A
- Continuous Duty: 100%ED
- EC Certification 

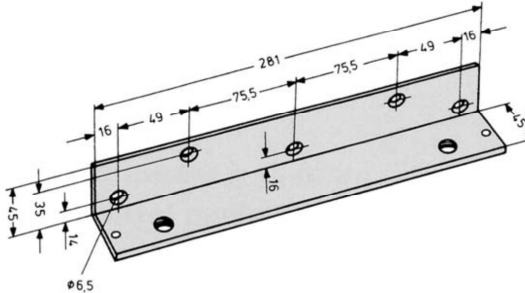
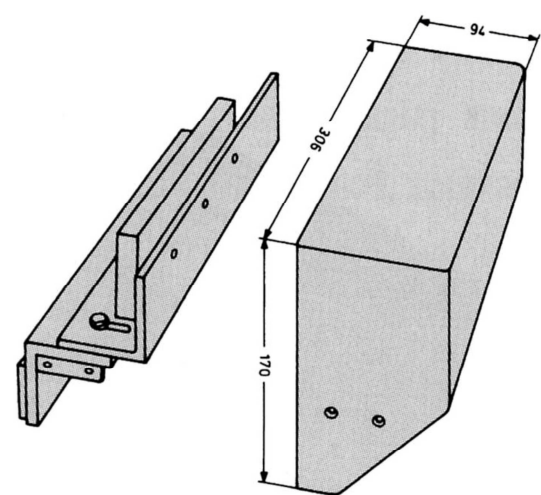

Accesories

		
Reference	828-4	828-6
Description	"L" bracket for lock	Adjustable "Z" bracket with plastic housing

